

16008B Resistivity Cell

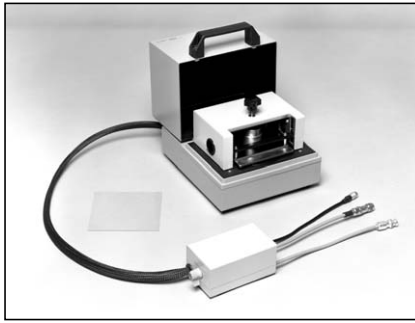

Terminal Connector:

Type	Connector
Input	Triaxial (special screw-type)
Output	High Voltage BNC (special type)
Control	Interlock connector*

* Interlock Connector enables and disables the application of source voltage from the measurement instrument.

DUT Connection: 2-Terminal (with triaxial cable)
Dimensions (approx.): 240(W) x 180(H) x 240(D) [mm]
Cable Length (approx.): 1.2 m (connector to electrodes)
Weight (approx.): 7000 g

Description: The 16008B is designed to operate specifically with 4339B. It is used to measure surface or volume resistance/resistivity of insulation materials. The following figures show the block diagrams of resistivity measurements.

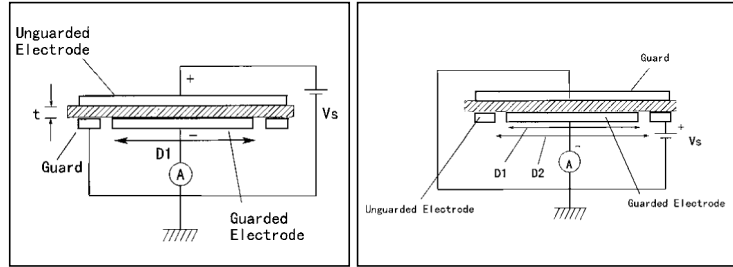

Volume resistivity measurement Surface resistivity measurement

Volume resistivity is measured across the material (MUT) by the unguarded and guarded electrodes. Surface resistivity, on the other hand, is measured along the surface of the MUT (between the guarded and the unguarded electrodes). Notice that the role of the guard and unguarded electrodes switch, when measuring volume and surface resistivity.

16008B is provided with three different electrode sizes to meet size requirements by different measurement standards. The guarded electrode eliminates measurement errors due to the edge effect and arbitrary contact pressure can be applied to the material under test. It is also equipped with a high-voltage protection cover to shut off power when opened.

Applicable Instruments: 4339B

Frequency: DC

Maximum Voltage: 1000 V

Maximum Current: 10 mA

Resistance Measurement Range:

Volume Resistivity Measurement Range:

up to $4.0 \times 10^{18} \Omega\text{cm}$

Surface Resistivity Measurement Range:

up to $4.0 \times 10^{17} \Omega$

Operating Temperature: -30°C to +100°C (excluding selector switch)

Material Size: Select an electrode so that outer diameter of guarding electrode is smaller than the DUT's diameter. See figure and table below for more details:

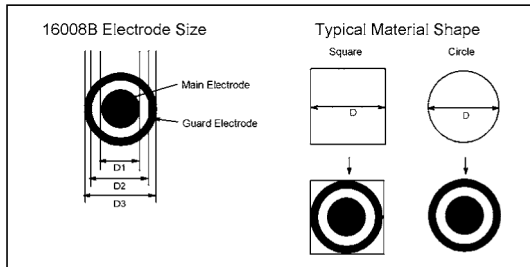

Electrode sizes and applicable material sizes

D1	D2	D3	Ordering information	D
Main Electrode	Guard Electrode (Inner Diameter)	Guard Electrode (Outer Diameter)	—	Material Size
26 mm	38 mm	48 mm	Supplied with Opt.16008B-001/002	50 mm* to 125 mm
50 mm	70 mm	80 mm	Standard - equipped	82 mm* to 125 mm
76 mm	88 mm	98 mm	Supplied with Opt.16008B-001	100 mm* to 125 mm

* Outer Diameter of Guard Electrode + 2 mm
 Thickness: 10µm to 10 mm

Furnished Accessories:

Description	P/N	Qty.
Operation and Service Manual	16008-90011	1

Options:

16008B-001: Add 26 & 76 mm diameter electrodes

16008B-002: Add 26 mm diameter electrode

Compensation and Measurement: Using the selector switch on the 16008B, select either the volume resistivity or surface resistivity measurement configuration. Open compensation is recommended before measurement and when the measurement configuration is switched. Separate the upper electrode from the main electrode by turning the contact pressure load knob until the upper electrode does not move. Then, close the top cover and perform open compensation. After open compensation, the material under test (MUT) is placed on the main electrode and the upper electrode is placed over it. Next, turn the load knob to adjust the electrode contact pressure on the MUT. Close the top cover and measure the MUT's surface or volume resistivity.

It is vital to make measurements, which are compatible to a certified test method (standard). It is shown below that the 16008B can make resistivity measurements which are compatible with ASTM D257 Standard Test Methods for DC Resistance or Conductance of Insulating Materials. In the figure and tables shown below, the size and shape is compared for two pairs of electrodes: one that is specified in ASTM D257 and the one that is used with the 16008B Resistivity Cell. The similarity implies that the 16008B is compatible with ASTM D257.

Note:

The main electrodes are orderable as a part by using following part numbers. Replace the main electrode when the conductive elastomer on the electrode comes off:

26 mm electrode: 16008-60083

50 mm electrode: 16008-60081

76 mm electrode: 16008-60085

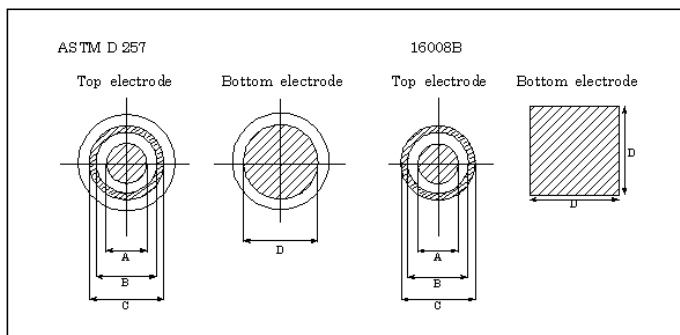

Compatibility with ASTM D257

ASTM D257's recommended electrode sizes

	Choice 1	Choice 2
A	76 mm	25 mm
B	88 mm	38 mm
C	100 mm	50 mm
D	100 mm	50 mm

16008B electrode sizes

	Opt. 16008B-001	Opt. 16008B-001/002
A	76 mm	26 mm
B	88 mm	38 mm
C	98 mm	48 mm
D	110 mm	110 mm